

250 KG TOOL CAGE

Maxirig

QUALITY LIFTING SOLUTIONS



A compact, general purpose tool cage designed for the carriage of smaller loads such as hand tools and materials but still maintaining full compliance with Australian Standards.

MAXIRIG PRODUCT CODE

GCG3025

DESCRIPTION

Work Load Limit:	250kg
Tare Weight:	30kg (excluding shackles or associated rigging gear)
Dimensions:	600mm (W) x 600mm (L) x 600mm (H)
Finish:	Y14 Golden Yellow

PRODUCT ASSURANCE

Parent Standard:	AS4991
Proof Load Testing	Yes
MPI Weld Inspection	Yes
Manufacturer's Guarantee	1 Year

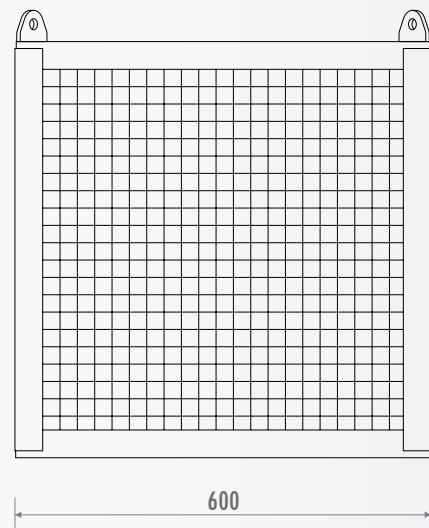
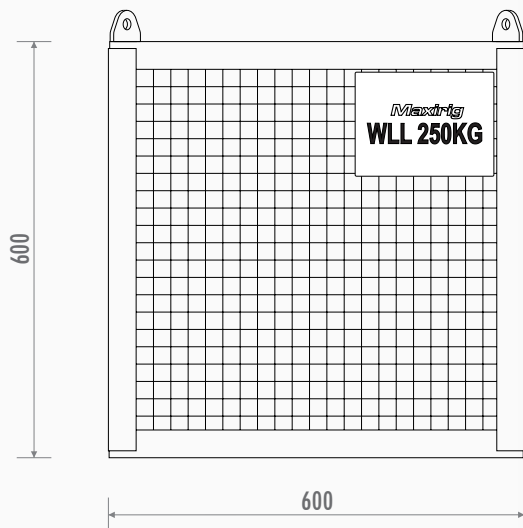

WE PROVIDE SUPERIOR QUALITY LIFTING PRODUCTS AUSTRALIA WIDE

All Maxirig products are designed and manufactured in Australia by our highly skilled team of engineers and boilermakers.

VISIT WWW.MAXIRIG.COM.AU