



Supplied with:

- ▶ Certification to AS4991-2004
- ▶ Proof load test certificate
- ▶ MPI welding report
- ▶ All welding to AS1554.1 SP
- ▶ Stainless steel compliance plate
- ▶ 2 pack painted finish (G36 Kikuyu Green)
- ▶ Australian Designed & Manufactured

WLL 2.5t (at 60° included sling angle)

For use with 1220mm pallets only
Approx TARE 0.020t

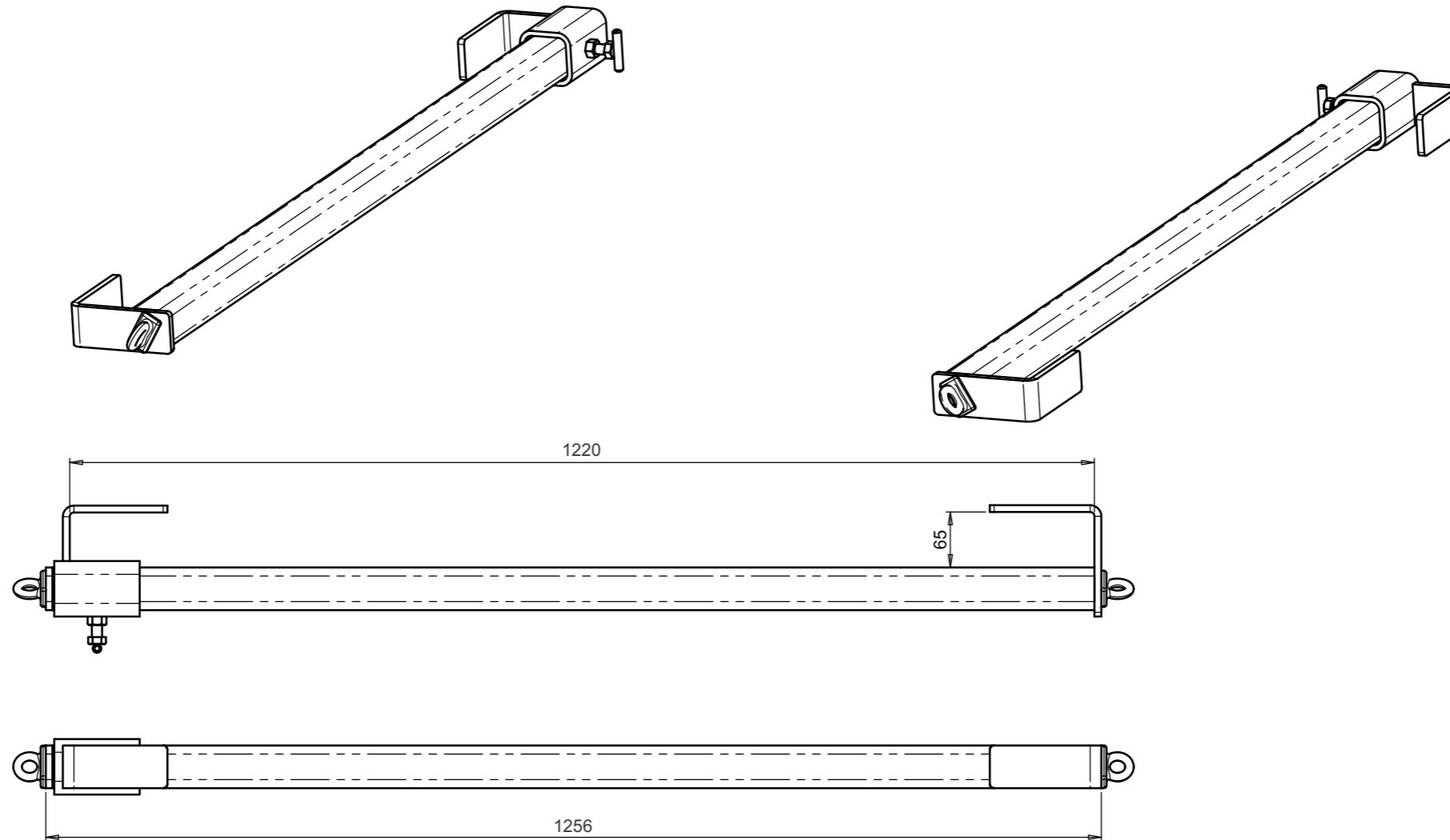

SKETCH NUMBER: Sk11742-1

REVISION: A

DRAWN BY: NVB

CONCEPT SKETCH ONLY - DO NOT SCALE

THIS SKETCH AND THE INFORMATION ON IT REMAINS THE PROPERTY OF MAXIRIG. WRITTEN PERMISSION MUST BE OBTAINED FROM MAXIRIG TO COPY OR REPRODUCE THE WHOLE OR PART OF THIS DRAWING.