

02.4

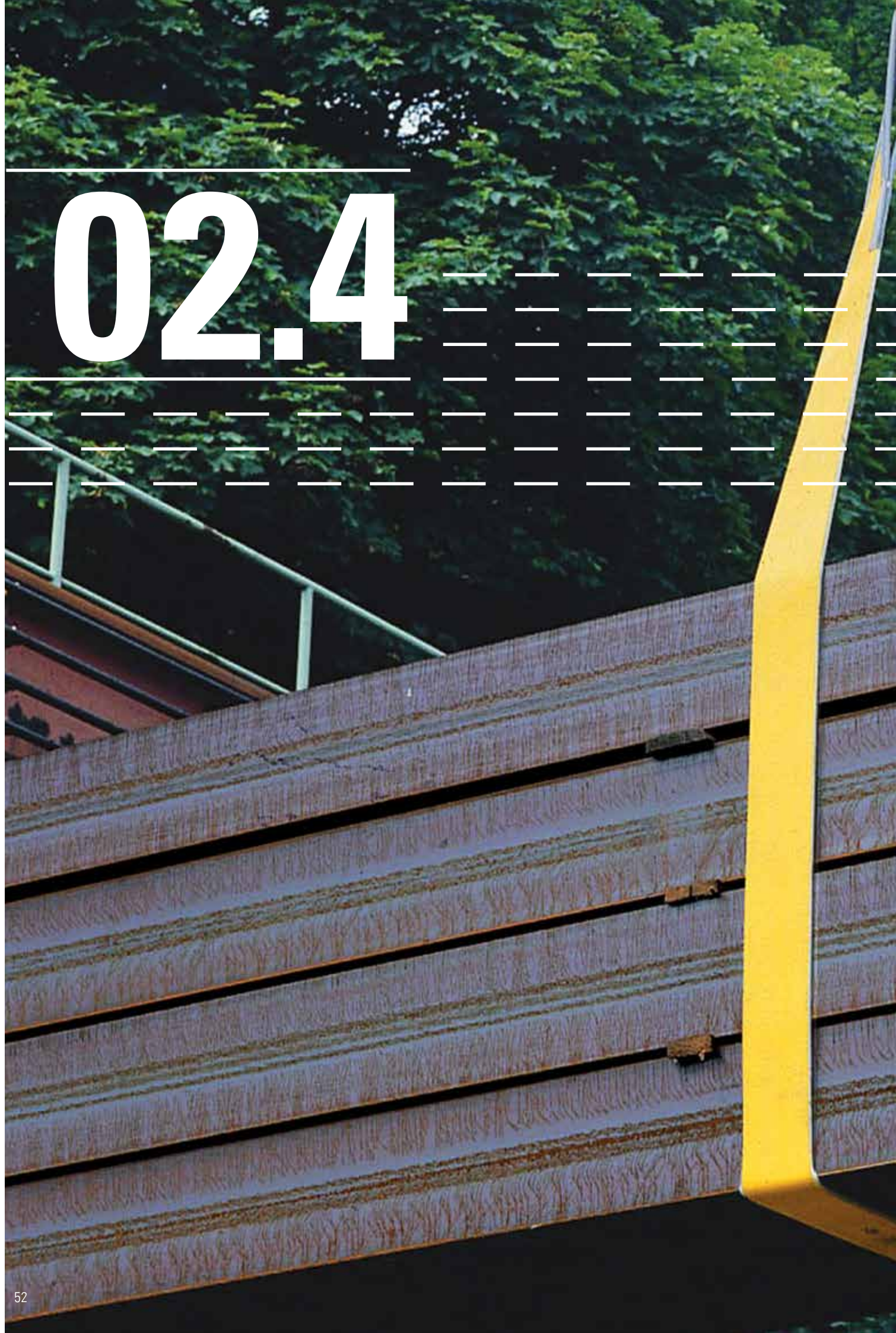

Cut Protection and Abrasion Sleeves

Cut Protection Sleeves	54-65
– secutex®	56-59
– NoCut® sleeve	58-61
Abrasion Sleeves	62-63
Buffer Products	64-65

02.4 CUT PROTECTION AND ABRASION SLEEVES

Cut Protection Sleeves

- secutex®
- NoCut®sleeve

Abrasion Sleeves
Buffer Products



secutex®

Secutex Sleeves

Secutex has been perfectly formulated with the optimum balance between flexibility, elasticity and toughness to protect synthetic slings from sharp edges and abrasion.

The sleeve grips the edge of the load, allowing the sling to move within the Secutex to self centre and adjust to the centre of gravity. This feature also allows the rotation of sharp objects, such as steel coils, without damage to the sling or products.

Sharp Edges

Slings attached directly around loads or structures. These can potentially move or slide when adjusting to the centre of gravity and as such represent the greatest risk and therefore demand higher radius criteria than attachment fittings.

What is a sharp edge?

If the radius (r) of the edge of the load is less than 3 times the compressed thickness (d) of the sling (AS4497).

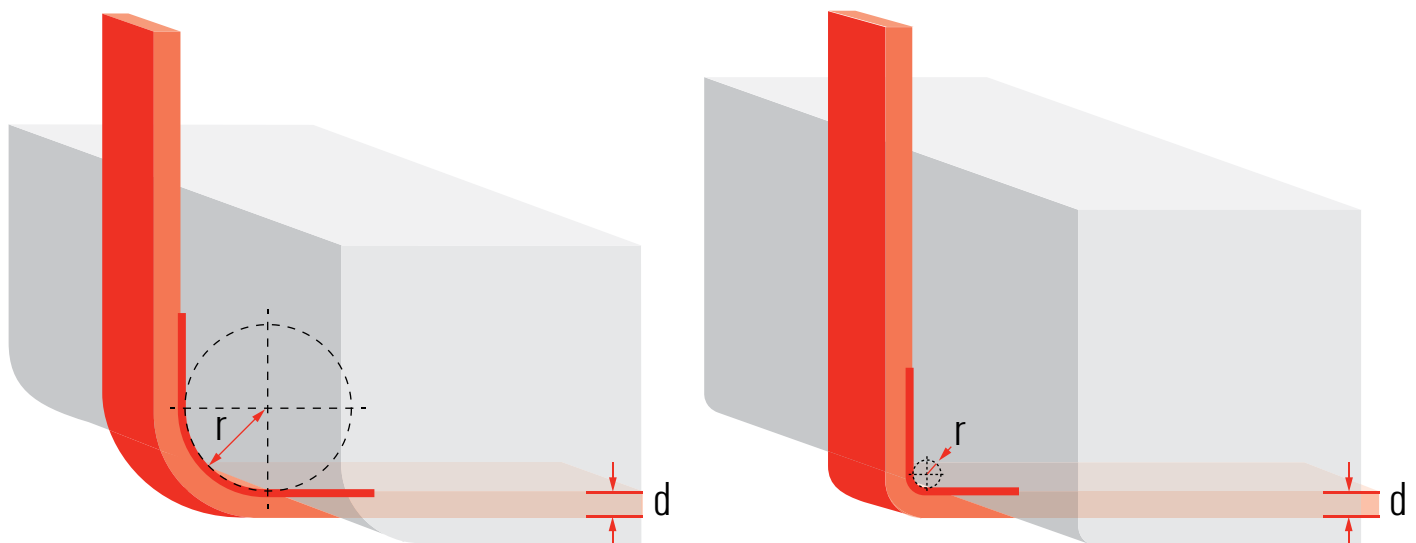

02.4 CUT PROTECTION AND ABRASION SLEEVES



Cut Protection Sleeves

- **secutex®**
 - NoCut®sleeve
- Abrasion Sleeves
Buffer Products

Sharp edges can take many forms and are not limited to an obvious razor sharp profile, these may also include:

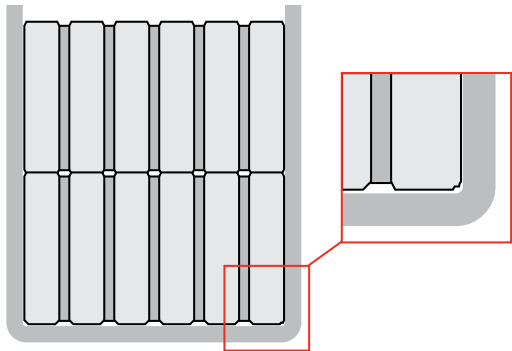

Objects with rough corners and edges such as rusted steel or scrap etc

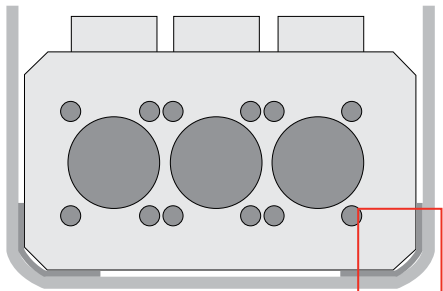

Objects with machined edges such as dies and tools etc

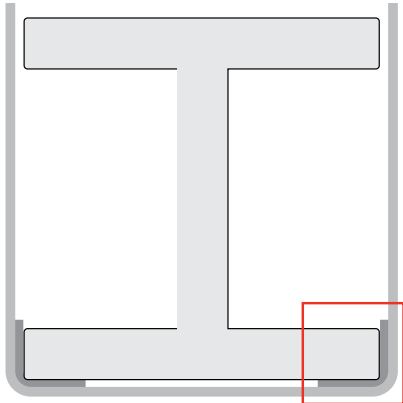

Objects with rolled edges but not of sufficient diameter such as steel beams etc

secutex®

Rotating Objects

The sling physically moves through the sleeve as the load rotates because the sleeve grips the load, allowing the free movement of the sling.

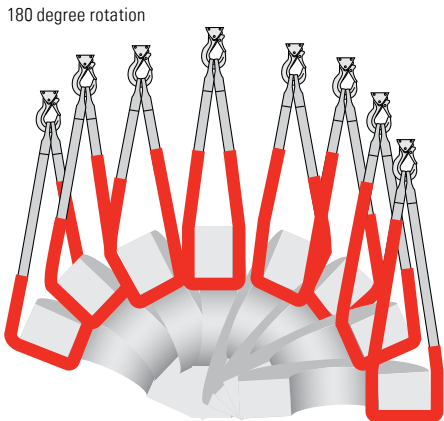
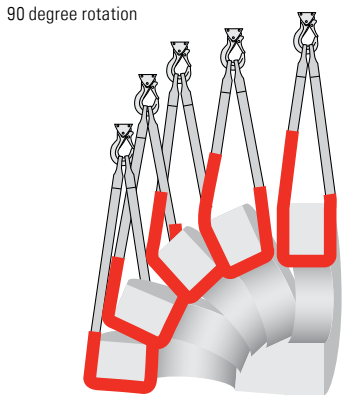

02.4 CUT PROTECTION AND ABRASION SLEEVES

Cut Protection Sleeves

- **secutex®**
- NoCut®sleeve

Abrasion Sleeves
Buffer Products



secutex®

secutex® is the market leader in coated lifting slings and protective sleeves, and secutex® products are used world-wide. With creativity and know-how, the range of possible applications is steadily growing. Because of their variety, secutex® products represent the economically and technically optimum solution again and again. Continuous and intensive production surveillance guarantees extraordinary product quality.

- Extreme cut-resistance
- Wear and abrasion resistance
- Smooth goods handling
- Lightweight for excellent handling
- Optimum work safety.

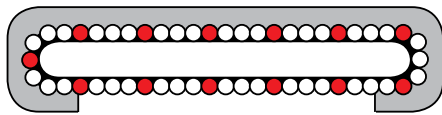

secutex® SF-1

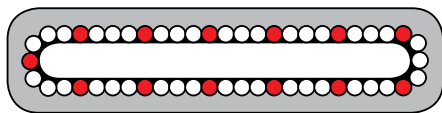

secutex® SF-2

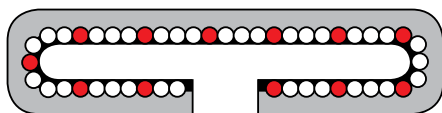

secutex® Clip-SC

Single Sided secutex®

- Fully encapsulates the sling with a hard wearing, flexible cut resistant surface on one side
- Difficult to retrofit
- Suitable for type 3 sleeve configuration.

Protective Sleeve SF-1 for Supra Plus, Magnum and Magnum Force Roundsling

Code	Internal Width (mm)	Height (mm)	Weight per running metre (kg)
SF1-50	70	22	0.9
SF1-75	95	22	1.3
SF1-100	120	22	1.5
SF1-150	170	22	2.1
SF1-200	220	35	2.7
SF1-250	270	35	3.2
SF1-300	325	35	4.0

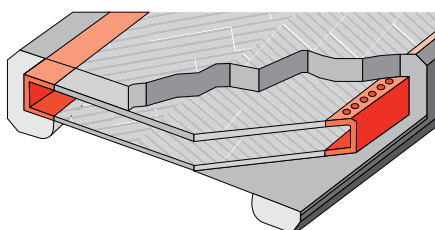

Double Sided secutex®

- Fully encapsulates the sling with a hard wearing, flexible cut resistant surface on both sides.
- Difficult to retrofit
- Suitable for type 3 sleeve configuration.

Protective Sleeve SF-2 for Supra Plus, Magnum and Magnum Force Roundsling

Code	Internal Width (mm)	Height (mm)	Weight per running metre (kg)
SF2-50	70	22	1.2
SF2-75	95	22	1.8
SF2-100	120	22	2.1
SF2-150	170	22	3.0
SF2-200	220	35	3.3
SF2-250	270	40	4.2
SF2-300	300	45	6.0

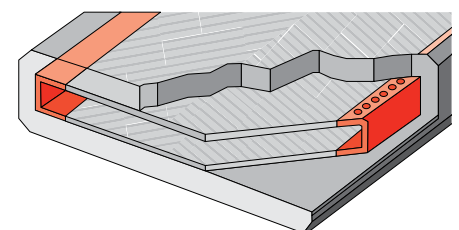



Clip-On secutex®

- Clips on to the sling with a hard wearing, flexible cut resistant surface on one side
- Easy to retrofit
- Suitable for type 3 & 5 sleeve configurations.

Protective Sleeve SC for Supra Plus, Magnum and Magnum Force Roundsling

Code	Internal Width (mm)	Height (mm)	Weight per running metre (kg)
SC-50	70	22	1.1
SC-75	95	22	1.6
SC-100	120	22	1.8
SC-150	170	22	2.6
SC-200	220	35	3.3
SC-250	270	40	4.2
SC-300	300	45	6.0

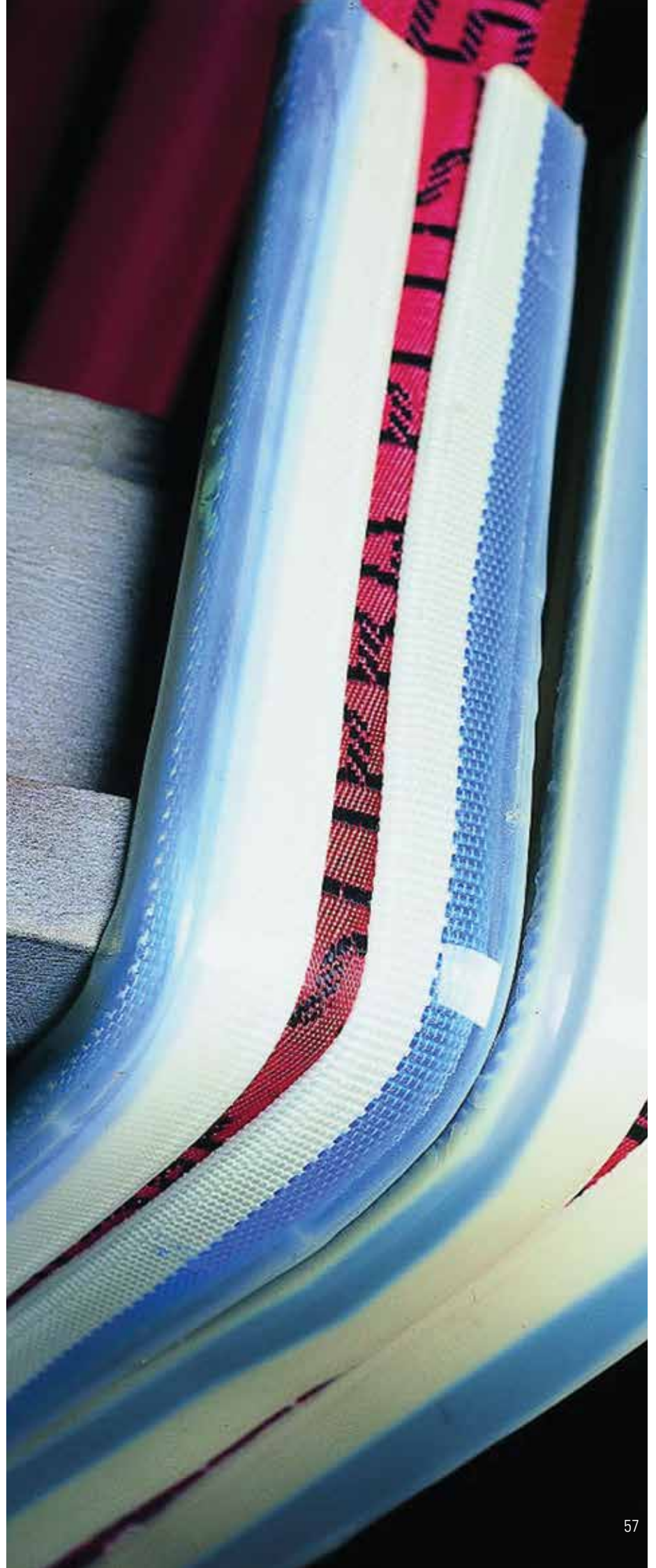
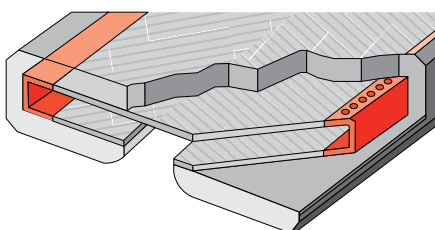

02.4 CUT PROTECTION AND ABRASION SLEEVES

Cut Protection Sleeves

- secutex®
- **NoCut® sleeve**

Abrasion Sleeves
Buffer Products

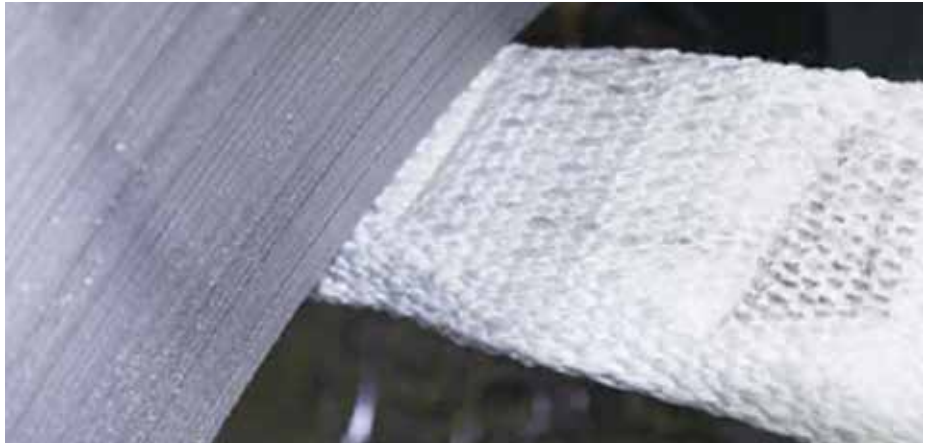

NoCut® sleeve High-tech Cut Resistant Sleeves

Do You Recognise This?

Handling sharp edged metal sheets, for instance, is often improvised and an insufficient solution is found: A pile of gloves or cardboard is used quite often as edge protection. This is against statutory regulations and can cause fatal accidents. Therefore protect your lifting gear with edge protection, which has been especially developed for sharp edges. Increase the service life of your lifting gear and improve your employees' safety.

SpanSet offers a solution with high performance edge protection from its selection of NoCut® products. NoCut® sleeve is a woven, protective, high performance sleeve for round slings and lifting belts, which is characterised by particularly high cut and abrasion resistance.

It goes without saying that NoCut® has been fitted according to the various widths of SpanSet lifting belts and round slings. Therefore NoCut® is best suited for the protection of textile lifting gear such as lifting belts and round slings, especially preventing damage caused by sharp edges when lifting heavy loads.

For More Safety

A special test system was designed and built for the development of NoCut®, which ascertains the cut resistance of a protective sleeve in realistic situations whereby the effect of a cut is loaded with a nominal load. This has determined the protective effect of NoCut® sleeve on edges with differing sharpness. Definite findings, which answer all application questions!



Its suppleness and minimal weight, compared to conventional products for cut protection, makes it easy to handle in many forms of application and ensures that time is saved when attaching.

NoCut® sleeve is woven from HMPE1 high performance fibres and offers the best protection for your textile lifting gear against cuts made by sharp edged loads. Rotating and turning loads is also no problem for NoCut® sleeve, and the special rib structure of the sleeve design makes it easier for the lifting gear to slide inside the sleeve. NoCut® sleeve protects the lifting gear even when a relative cutting motion takes place, which can occur when a load is raised. Such relative movements between load and edge protection are permissible in the case of edge radii of more than 1mm, as long as they do not exceed the

usual setting characteristics by more than a few centimetres when raising a load. If SpanSet prepares the lifting process in collaboration with technical engineers in such a way that the edge protection and the load do not shift when raised, then cut protection is even ensured for radii of under 1mm.

The NoCut® sleeve is supplied ready-to-use with trimmed cut edges. Protective sleeves are offered with lengths of 250mm sections and widths of 30mm to 300mm as standard.

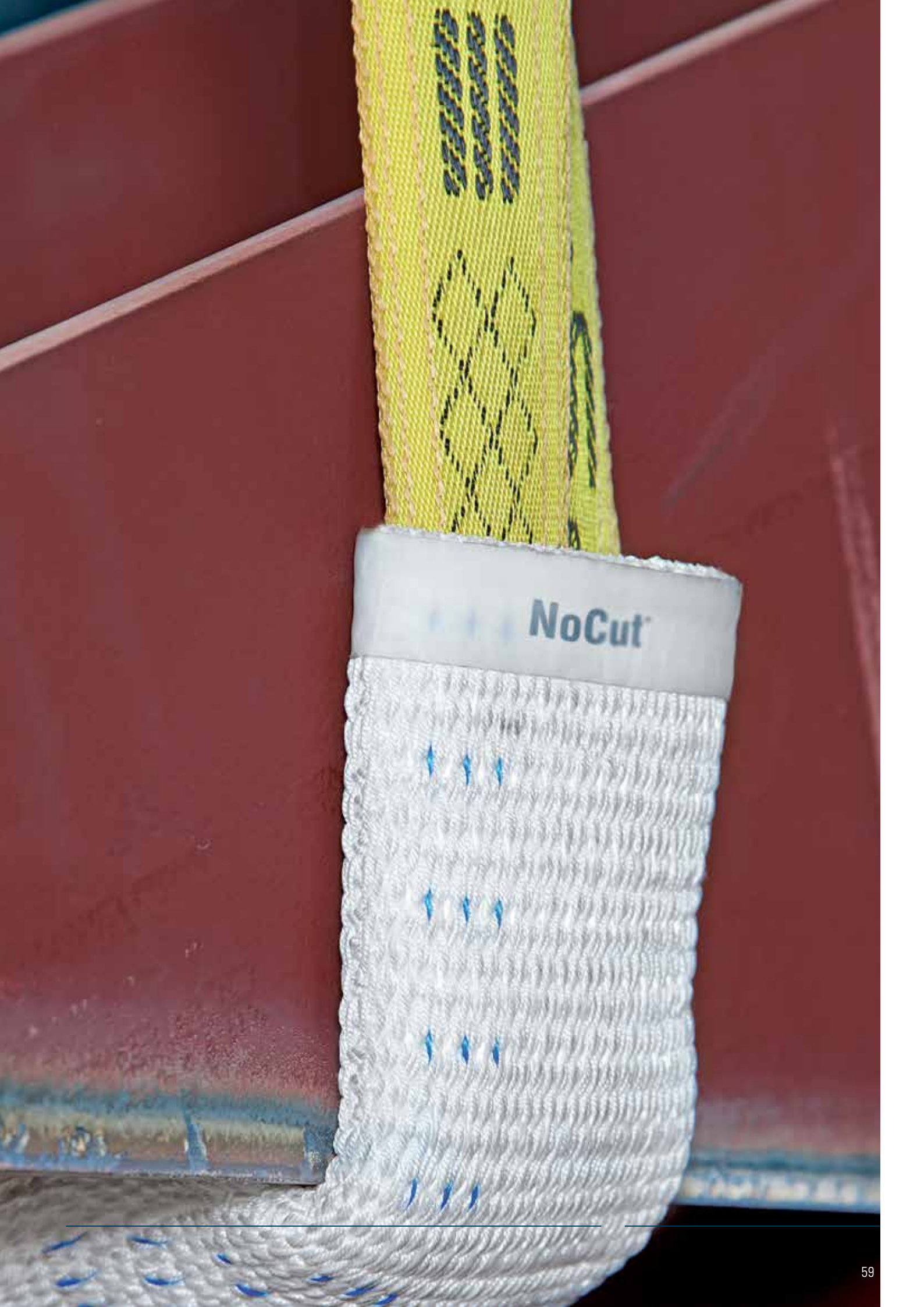

NoCut

02.4 CUT PROTECTION AND ABRASION SLEEVES

Cut Protection Sleeves

- secutex®
- **NoCut® sleeve**

Abrasion Sleeves
Buffer Products



NoCut® sleeve High-tech Cut Resistant Sleeves

NoCut® Sleeves Technical Information

Circa Sleeve Inner Width (mm)	Circa Sleeve Width (mm)	Circa Sleeve Height (mm)	Compatible With Flatslings	Compatible With Roundslings
45	55	13	B1000	
75	85	13	B2000	SpanSet 1000, 2000
105	115	13	B3000	SpanSet 3000 SupraPlus 3000 Magnum Force 10000

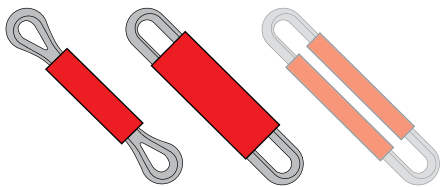

The two types on the left are available. The type on the right is available on request.



Textile protection against cuts with minimal net weight.

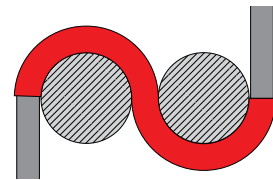

Supple and flexible design.

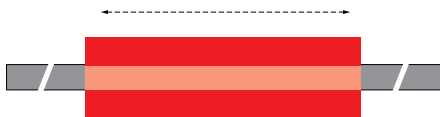

Usable on both sides. Slides along its entire length.



Tested protection against cuts.

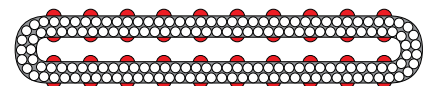

Unique rib structure.

Right: NoCut® sleeve is not tensed when loaded – you can see this by the way it gathers. This avoids premature wear and tear.

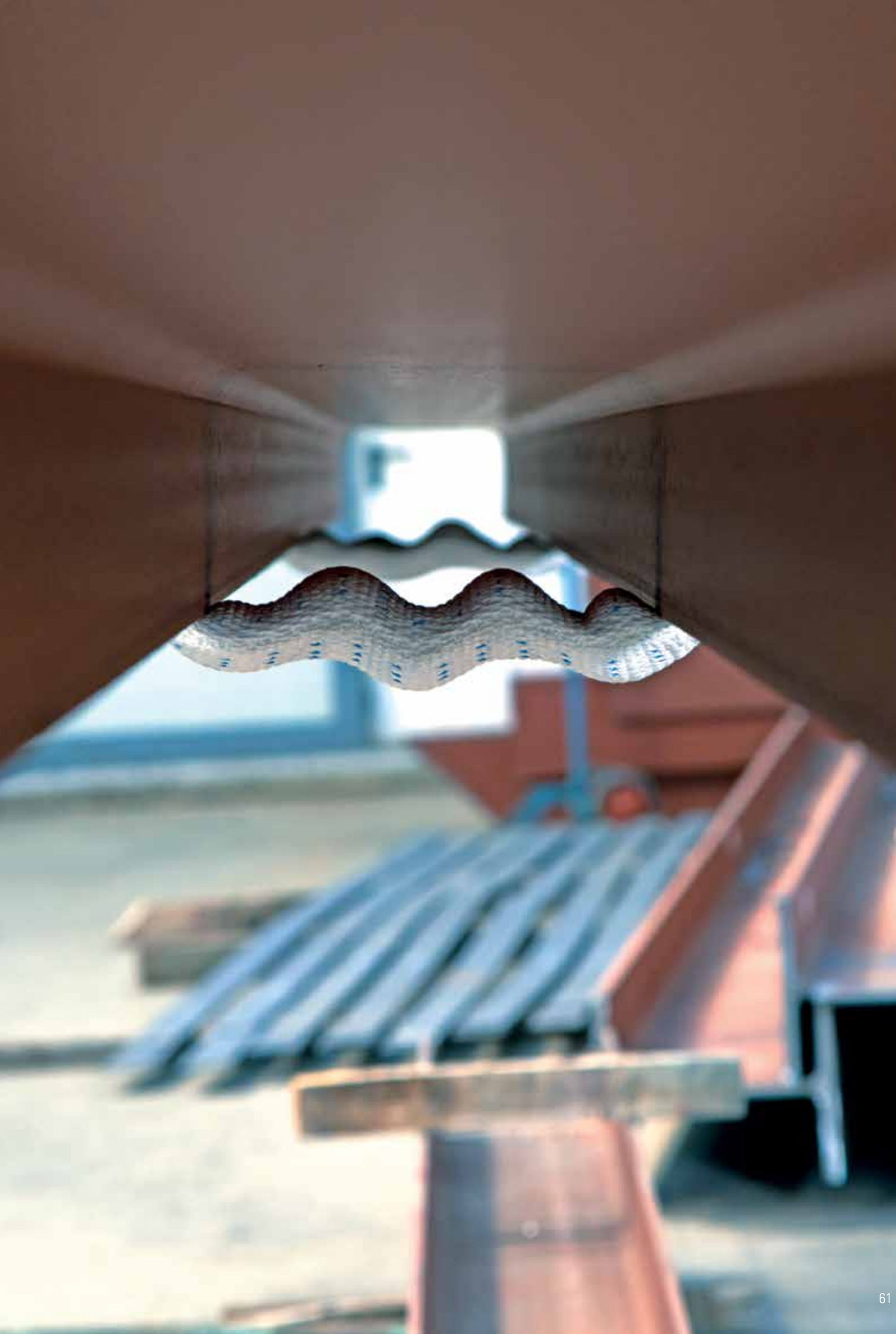

02.4 CUT PROTECTION AND ABRASION SLEEVES

Cut Protection Sleeves

- secutex®
- NoCut®sleeve

Abrasion Sleeves

Buffer Products



Abrasion Sleeves

SpanSet protective sleeves are designed to lengthen the life of flat webbing and round slings.

They protect against abrasion and dirt ingress and are generally permanently attached to the sling, though some are removable.

They are not for protection against sharp edges, in which case secutex® sleeving must be used.

Hi-Tech Webbing Sleeves

Heavy duty sling webbing is used for high abrasion applications.



Hi-Tech Webbing Sleeves

Kooper Sleaving

Light weight with a smooth abrasion resistant surface.



Kooper Sleaving

Lay Flat Hose

Light weight PVC moisture resistant hose.



Lay Flat Hose

Sleeve Configurations



Type 1 – Flat sling



Type 2 – Flat sling



Type 3 – Over double leg round sling

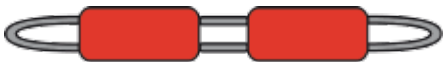

Type 4 – Round sling



Type 5 – On single leg round sling

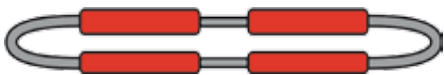

Type 6 – Round sling



02.4 CUT PROTECTION AND ABRASION SLEEVES

Cut Protection Sleeves

- secutex®
- NoCut® sleeve

Abrasion Sleeves

Buffer Products



secutex® Buffer

secutex® Buffer

Using variations of the patented secutex® formula, Buffer products offer many cost saving advantages to everyday situations. They offer additional grip when handling objects as well as limiting the damage to the product when doing so.

Brick and Tile Grippers

These have proven to be of enormous benefit to the brick and tile industry thanks to the soft yet durable buffer pads used on the grippers. Traditionally these grippers have been faced with rubber which was glued on. The secutex® Buffer pads have a steel mesh backing which can be drilled and bolted to the tynes, making replacement much faster. The Buffer has been known to last for over two years in continuous service, saving downtime and damage to the products.



Buffer Pads



Fork Shoes



Buffer Pads



Fork Shoes



Tile Grippers



Brick Grippers



C Hook Liners



Fork Shoes

When transporting steel pallets or coils there is a real hazard of the load sliding off the forks if there is sudden braking or an evasive manoeuvre.

The tough secutex® fork coating allows the steel object to dig in and add much needed friction for a slip resistant performance.

Contoured profiles, such as those used for carrying coils, eliminate any damage to the product previously cause by the metal to metal contact.

C Hook Liners

Ideal for lifting coils and steel objects, with the added safety of slip resistance and the cost benefits of less damaged product.



C Hook Liners

